



THERMIC FLUID HEATER

www.cheemaboilers.com

THERMIC FLUID HEATER

A Thermic Fluid Heater is industrial heating equipment, used where only heat transfers are desired instead of pressure. In this equipment, a thermic fluid is circulated in the entire system for heat transfers to the desired processes. Combustion process heats up the thermic fluid, and this fluid carries and rejects this heat to the desired fluid for concluding the processes. After rejecting it, this fluid comes back again to the thermic fluid heater.

CBL Thermic Fluid Heater stands as an optimal solution amongst the dynamic energy scenario. The vertical design offers compactness across various multi fuel flexibility which makes it an ideal choice for heating applications in Textile, Chemical, Plywood, Food & Beverages, Pharmaceutical, Rubber, Solvent, Edible Oil and all other industries requiring indirect heating.

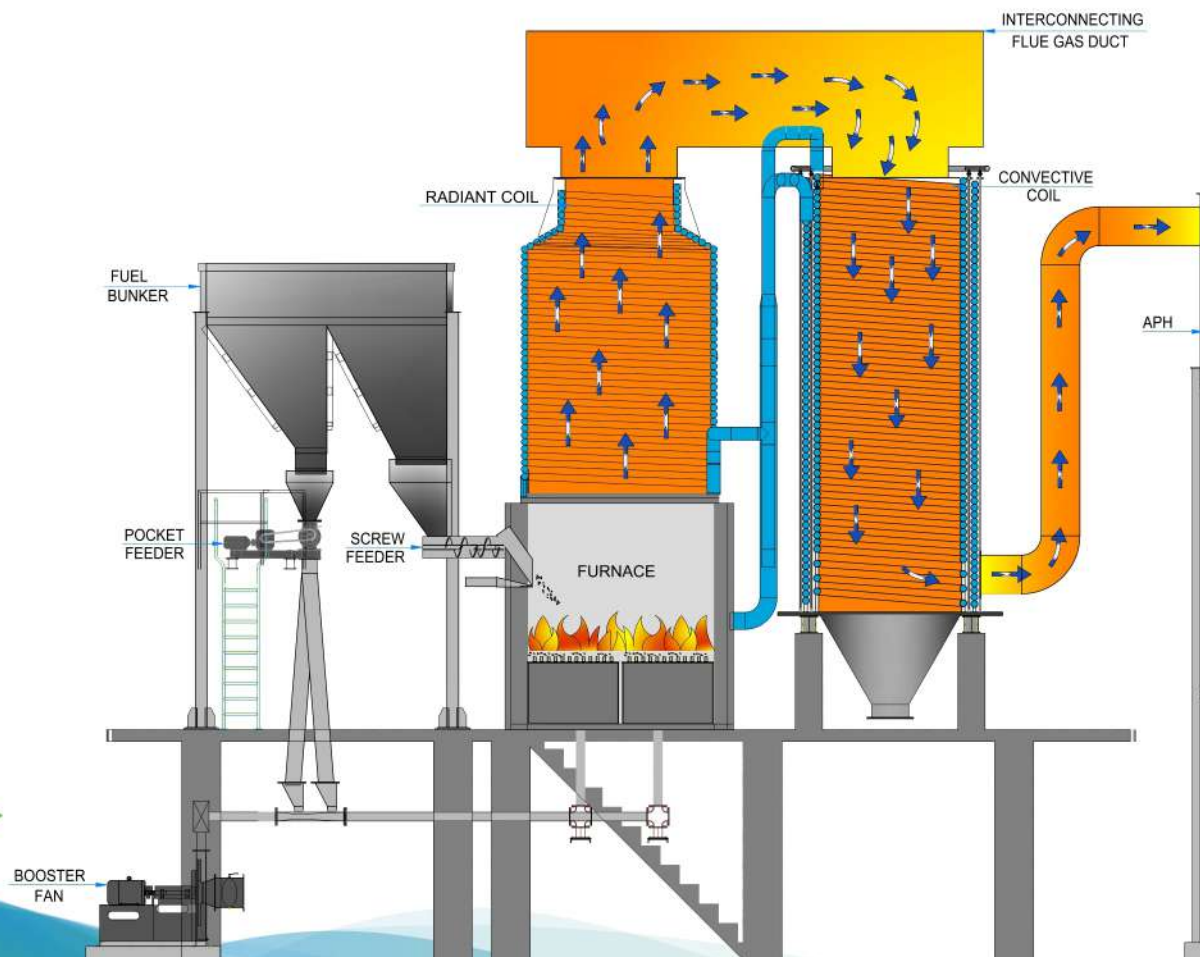

Unique Design Features

- Furnace design suitable for low grade fuels.
- Minimum exposed surface reducing radiation/convective losses.
- Large feeding door for ease of feeding.
- Large furnace volume for efficient combustion.
- Air pre-heater improves combustion efficiency and ensures lower power consumption of ID fan.
- Design adopts principles of DIN and API codes
- Occupies Minimum space and site work.
- Quick and easy installation.
- Safety relief valve to prevent high pressure.

85%
Efficiency

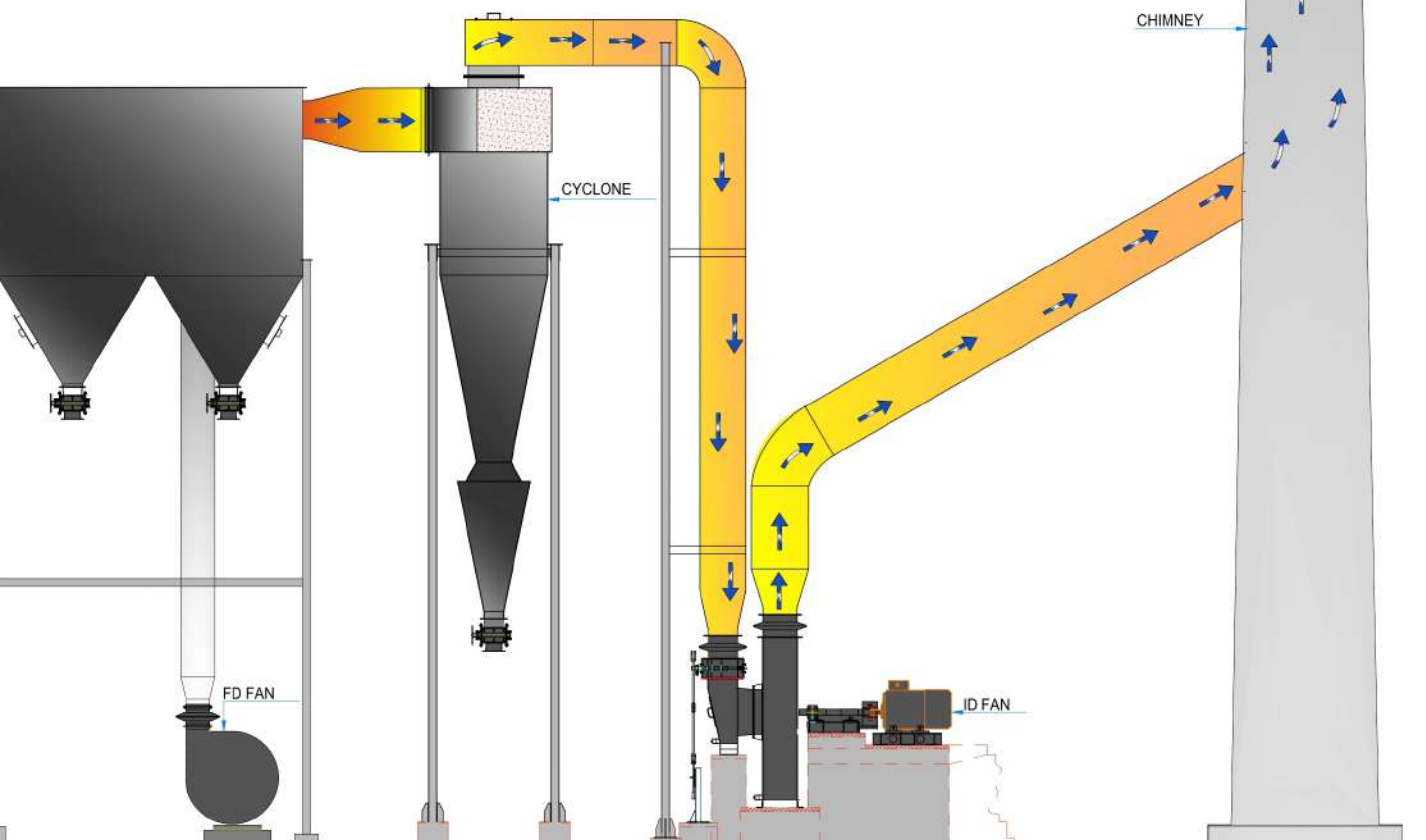

OUR OFFERINGS

CPP/IPP

- ⊙ Power Boilers
 - ⊙ Atmospheric Fluidized Bed Combustion Boiler (AFBC)
 - ⊙ Travelling Grate/Dumping Grate/Pulsating Grate/ Reciprocating Grate / Water Cooled Vibrating Grate
- ⊙ Waste Heat Recovery Boilers (WHRB)
- ⊙ Slop Fired Boilers

Process Industrial Boilers

- ⊙ Hypac - AFBC
- ⊙ Energypac - Grate Fired
- ⊙ Energypac Plus
- ⊙ Oil / Gas Fired
- ⊙ Effypac - Manual / Auto Fired

Retrofit and Spares

- ⊙ Spares for Boilers / TFH
- ⊙ Structures
- ⊙ Centrifugal Fans
- ⊙ Boiler Services
 - ⊙ Annual Service Contract
 - ⊙ Engineering & Operation audit of Boilers
 - ⊙ O&M Services
 - ⊙ RLA/ Health audit of Boiler
- ⊙ Pollution Control Equipment's
 - ⊙ Electrostatic Precipitators (ESP)
 - ⊙ Bag Filter
 - ⊙ Cyclones
 - ⊙ Wet Scrubber
- ⊙ Automation

Boiler Water Solution

- ⊙ Pre-Treatment
 - ⊙ Clarification
 - ⊙ Filtration
- ⊙ Resin Based System
 - ⊙ Demineralization (DM)
 - ⊙ Softeners
 - ⊙ Electrodeionization (EDI)
- ⊙ Membrane Based System
 - ⊙ Reverse Osmosis (RO)
 - ⊙ Nanofiltration (NF)
 - ⊙ Ultrafiltration (UF)
- ⊙ Water Recycling System
 - ⊙ Zero Liquid Discharge Systems (ZLD)

SERVICE SUPPORT - 24x7
Tel: +91-7777881225



CBL quality standards are inspected and certified by prestigious global agencies like:



Certifications and Accreditations

- ISO 9001:2015
- ISO 14001:2015
- ISO 45001:2018
- ISO 3834-2:2005
- EN1090-1:2009 + A1: 2011
- EN1090-2:2018
- ASME 'U', 'S' & 'H' Certificates

CHEEMA BOILERS LIMITED

HEAD OFFICE: D-188, Sector 74,
Mohali, Punjab (India)-160071
Tel: +91-172-5090 487, 5055 666,5091790
Email : marketing@cheemaboilers.com

WORKS: Banmajra, Kurali, Distt. Ropar,
Punjab (India) Tel: +91-160-5005 800-02

SALES & SERVICES OFFICE:

Delhi NCR | Ahmedabad | Mumbai
| Kolkata | Hyderabad | Chennai

Follow us on :    

Types of Furnace

Reciprocating Grate

- Capacity upto 50M kcal/hr
- Temperature upto 300°C
- Fuel: Rice Husk, Coal, Bagasse, Wood Chips, Mustard Husk, Paddy Straw, Palm Fiber, Briquettes, Pellets.

Features

- Suitable for complex and versatile Biomass fuels.
- Robust construction with minimum maintenance, resulting in longer life and reliable operation.
- High alloy steel air-cooled grate bars.
- Efficient combustion due to better air distribution.
- The sloped air-cooled reciprocating grate appears inclined ladder shape that make the fuel move towards ash discharge end easily.

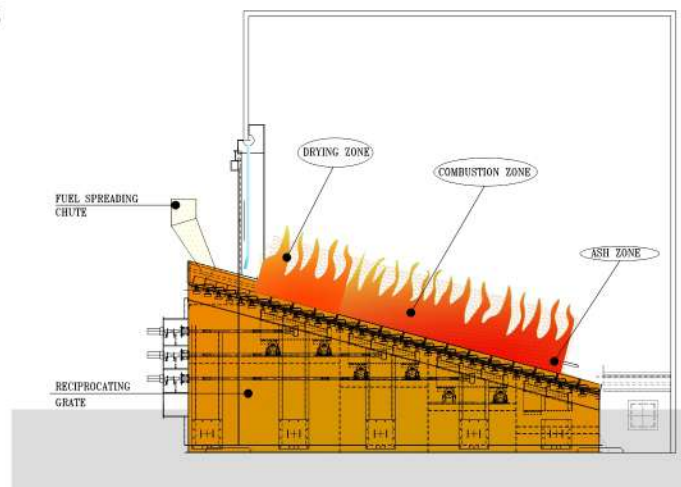

AFBC

- Capacity upto 50M kcal/hr
- Temperature upto 300°C
- Fuel: Rice Husk, Coal

Features

- High efficiency.
- Fast response to load fluctuations.
- High reliability (Reduce Maintenance Cost)
- Flexibility on versatile fuels.
- Maximum Fuel & Auxiliary power saving.
- Simple operation & quick startup.

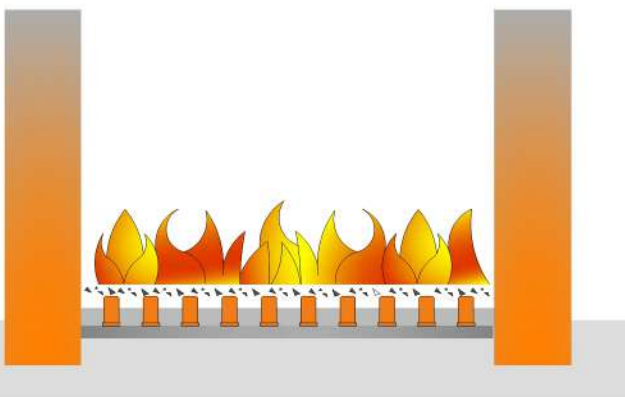

Plain Grate

- Capacity upto 20M kcal/hr
- Temperature upto 300°C
- Fuel: Rice Husk, Coal, Bagasse, Wood Chips, Mustard Husk, Briquettes

Features

- SWIRLING air injection for better post combustion burning fuels.
- Ability to fire moist fuel
- Manual and auto fuel feeding options.
- Highly efficient low speed fans.
- Anti-abrasive coating in the cyclones.
- High grade cast iron fire doors.

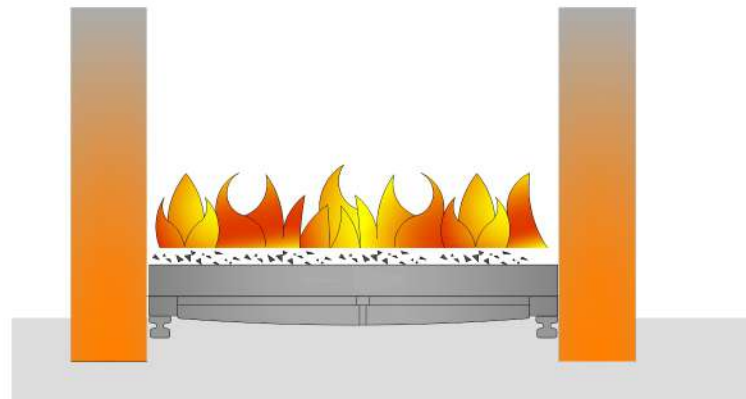

Oil / Gas

- Capacity upto 50M kcal/hr
- Temperature upto 300°C
- Fuel: LDO, HSD, NG, PNG

Features

- In this system separate servo motors are installed for air dampers, fuel regulator and combustion head control to optimize air flow pressure loss in the combustion head. The ratio between fuel, combustion air and air flow is adjusted electronically.
- This system also takes care of burner control and safety functions.
- It can be connected to external system via bus interface (Modbus, Profibus).
- On/Off/ step less modulation options are available.
- Option for external APH (efficiency upto 92%)

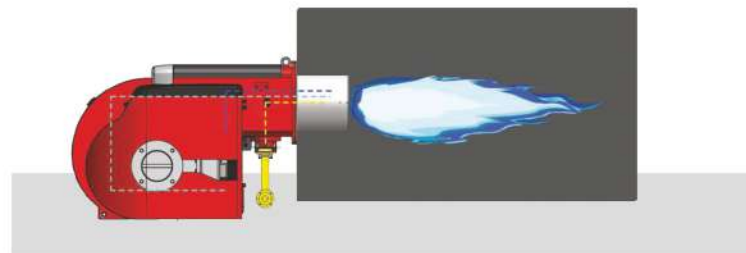

Deaerator Cum Expansion Tank

- It comes with a buffer vessel to prevent cooling of hot oil coming from the process.
- The tangential thermic fluid entry in the deaerator ensures optimal deaeration.
- Requires less space.

